

Wide Area Squeegee

Model No:
470000
470033

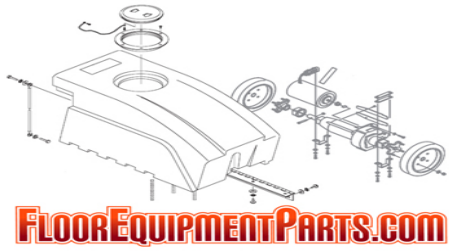

Optional Squeegee
Assembly
15/20 Gallon
Poly Tanks

OPERATION

SERVICE

PARTS

CARE

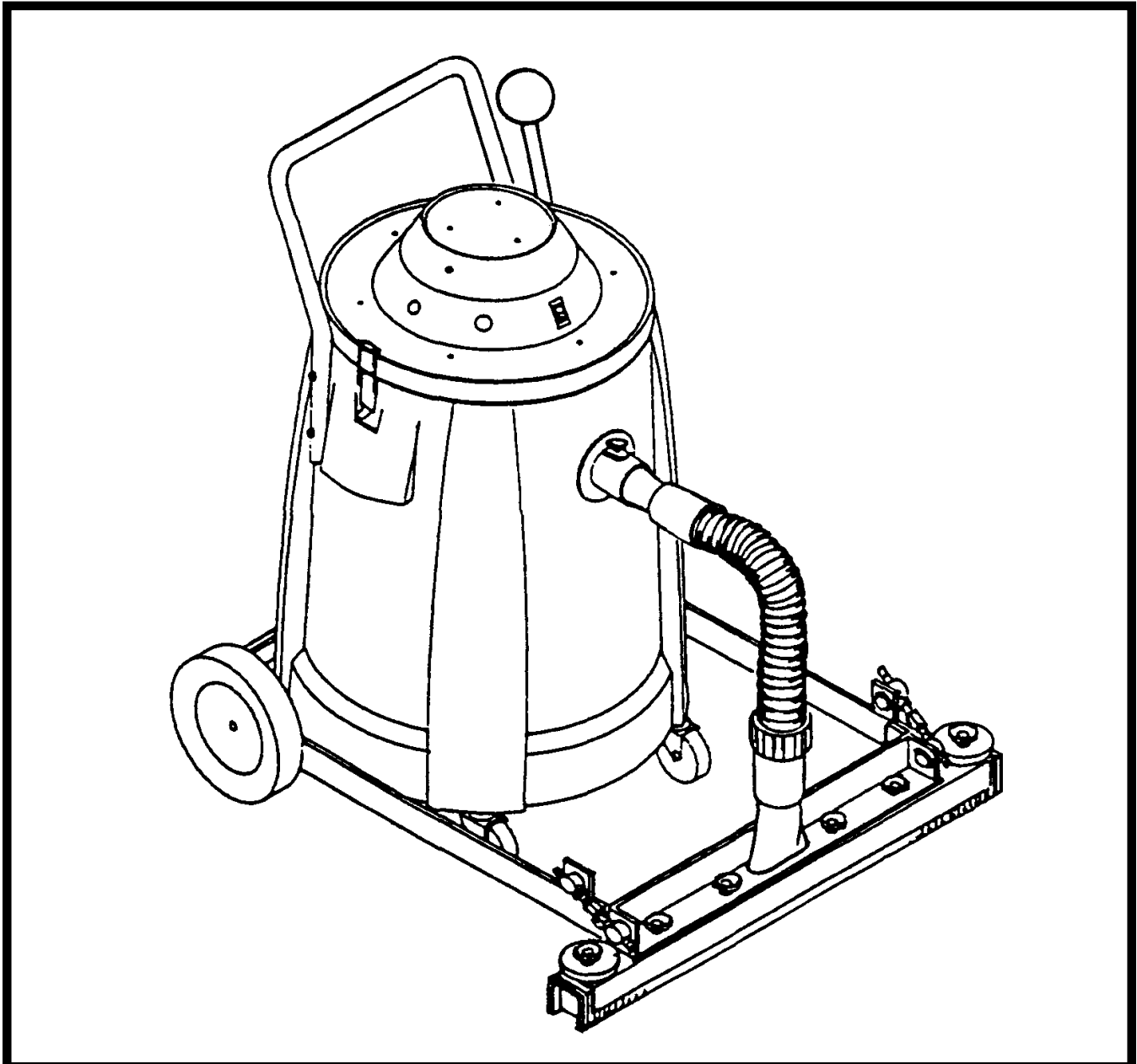

Revised 1/04

Minuteman[®]

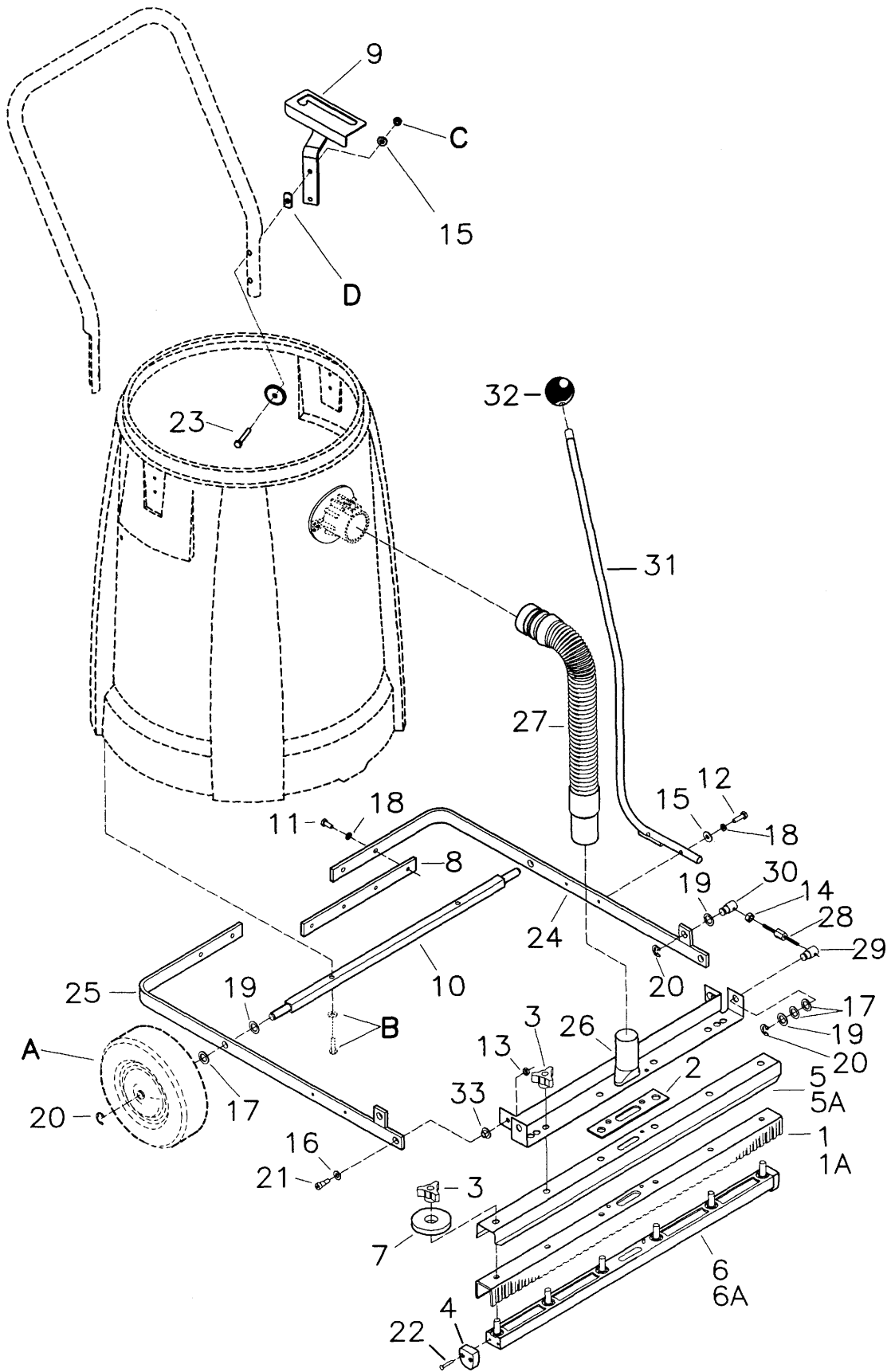

PARTS LISTING

ITEM	PART	QTY	DESCRIPTION	ITEM	PART	QTY	DESCRIPTION
1	11-145	1	Squeegee Gum Rubber (470000)	16	711506	2	WSR-Flat 5/16 (Narrow) STPL
1A	210065	1	Squeegee Blade 200 Gum (470033)	17	711524	6	WSR-Wave .52 x .87 x .01
2	430073	1	Gasket Diecut PS Back	18	711544	6	WSR-Helical 1/4
3	430074	6	Adjusting Nut 17B/E	19	711594	6	WSR-Flat .56 x .88 x .03 Nickel
4	430076	2	Nylon Squeegee Insert	20	711713	6	Ret Ring-E Ext .50
5	430078	1	U Profile (470000)	21	712041	2	BLT-Shoulder 1/4-20 x .44 x .3
5A	210024	1	Squeegee U Profile (470033)	22	712517	4	SCR-MC FL HD 8/32 x 1 SS
6	430079	1	Casting Squeegee Asy (470000)	23	712569	2	SCR-MC 1/4-20 x 1.50 SS
6A	210023	1	Squeegee Casting Asy (470033)	24	750137	1	Bkt Arm Squeegee Asy Left
7	430085	2	Squeegee Bumper Wheel	25	750138	1	Bkt Arm Squeegee Asy Right
8	470001	1	Brace Rear	26	750139	1	Squeegee Mtg. Bkt. Asy
9	470005	1	Lever Lock Asy	27	750140-1	1	Vac Hose Asy w/new cuff
10	470007	1	Axle Squeegee Asy	28	750689	2	Stud, Adjusting
11	711203	4	BLT-HH 1/4-20 x .62 STL ZINC	29	762256PLT	2	Nut Adj. LH Zinc PLT
12	711206	2	BLT-HH 1/4-20 x .87 STL ZINC	30	762257PLT	2	Nut Adj. RH Zinc Dicromat
13	711377	2	Nut-Lock 1/4-20	31	807384	1	Rod Handle
14	711420	2	Nut-Hex Jam 5/16-18 STPL	32	807385	1	Knob Handle
15	711505	2	WSR-Flat 1/4	33	829052	2	Bushing-FLG .312 x .437 x .31

INSTALLATION INSTRUCTIONS 470200 SQUEEGEE ASSEMBLY

1. Turn existing tank upside down and remove both wheels (A) by removing snap ring 20 from existing axle.
2. Remove screws and washers (B) from existing axle and remove old axle.
3. Reinstall wheels onto new axle assembly with new E clip provided.
4. Install new axle - squeegee assembly to bottom of tank using existing screws "B" and tighten securely.
5. Turn tank assembly to upright position and remove acorn nuts (C) and weld nuts (D). Replace existing screws with new screws, item 23, and keep existing washers. secure with weld nut (D). Mount item 9 to new screws with washers, item 15, and acorn nuts (C).
6. Slide Item 31 through Item 9 and mount to Item 24 with bolts supplied.

ADJUSTMENTS

1. Angle of squeegee assembly can be adjusted if needed, by loosening nut 14 and turning item 28. Both sides may need adjusting so that squeegee blade is parallel to floor in down position.
2. 15 Gallon Units Only: Vac hose assembly, Item 27, should be shortened by 4" to remove excess length.

LIMITED WARRANTY

Minuteman International, Inc. warrants to the original purchaser/user that this product is free from defects in workmanship and materials under normal use and service for a period of three years from date of purchase. In addition, Minuteman International, Inc. will, at its option, honor labor warranty claims for the first 12 months from date of sale, provided such claims are submitted through and approved by factory authorized repair stations. Minuteman International, Inc. will, at its option, repair or replace without charge, except for transportation costs, parts that fail under normal use and service when operated and maintained in accordance with the applicable operation and instruction manuals.

This warranty does not apply to normal wear, or to items whose life is dependent on their use and care, such as belts, cords, switches, hoses, rubber parts, electrical motor components or adjustments. Parts not manufactured by Minuteman International, Inc. such as engines, batteries, battery chargers, hydraulic pumps, and tires are covered by and subject to the warranties and/or guarantees of their manufacturers. Please contact Minuteman International, Inc. for procedures in warranty claims against these manufacturers.

Special warning to purchaser — Use of replacement filters and/or prefilters not manufactured by Minuteman International, Inc. or its designated licensees, will void all warranties expressed or implied.

A potential health hazard exists without exact original equipment replacement.

All warranted items become the sole property of Minuteman International, Inc. or its original manufacturer, whichever the case may be.

Minuteman International, Inc. disclaims any implied warranty, including the warranty of merchantability and the warranty of fitness for a particular purpose. Minuteman International, Inc. assumes no responsibility for any special, incidental or consequential damages.

This limited warranty is applicable only in the U.S.A. and Canada, and is extended only to the original user/purchaser of this product. Customers outside the U.S.A. and Canada should contact their local distributor for export warranty policies. Minuteman International, Inc. is not responsible for costs or repairs performed by persons other than those specifically authorized by Minuteman International, Inc. This warranty does not apply to damage from transportation, alterations by unauthorized persons, misuse or abuse of the equipment, use of non-compatible chemicals, or damage to property, or loss of income due to malfunctions of the product.

If a difficulty develops with this machine, you should contact the dealer from whom it was purchased.

This warranty gives you specific legal rights, and you may have other rights which vary from state to state. Some states do not allow the exclusion or limitation of special, incidental or consequential damages, or limitations on how long an implied warranty lasts, so the above exclusions and limitations may not apply to you.

Minuteman[®]

World Headquarters
Minuteman International, Inc.
111 South Rohlwing Road
Addison, Illinois 60101

Minuteman Canada, Inc.
2210 Drew Road
Mississauga, Ontario
L5S 1B1

(630) 627-6900
FAX (630) 627-1130

(905) 673-3222
FAX (905) 673-5161

987317
Printed in U.S.A.